

## Instruction Leaflet and Parts List No. IN 15

## Maximum and Minimum Limit Stops for Series 'G' Diaphragm Actuators (See also Leaflet IN 02 for Basic Actuator)

Maximum and minimum limit stops are designed to restrict valve travel in either upward or downward direction

Both versions are fully adjustable over full valve travel, but after adjustment, they should be locked in position with locknuts (523) – they are NOT intended for regular use as jacking screws.

The illustrations in this leaflet show the assemblies mounted on DIRECT (air fail upwards) actuators, but the procedure for fitting is identical for REVERSE (air fail downwards) actuators – see leaflet IN – 02 for basic actuator assembly.

**Maximum Opening -** Restricts upward movement of actuator.

### Installation

1. Remove aluminium cover plate (540) and cover plate joint (559) as supplied on basic actuator.
2. Remove protective cap (610) from sub-assembly and slacken locknut (523B).
3. Place sub-assembly on top of actuator and fasten down with cover plate screws (594).

NB – On Direct actuators, apply smear of light grease or oil to end of spindle (607) where it passes through 'O' rings (564).

### Adjustment

1. Apply air to actuator.
2. Move actuator up and down whilst screwing spindle (607) downwards until desired travel is obtained.
3. Lock in position with locknut (523B) and replace cover (610).

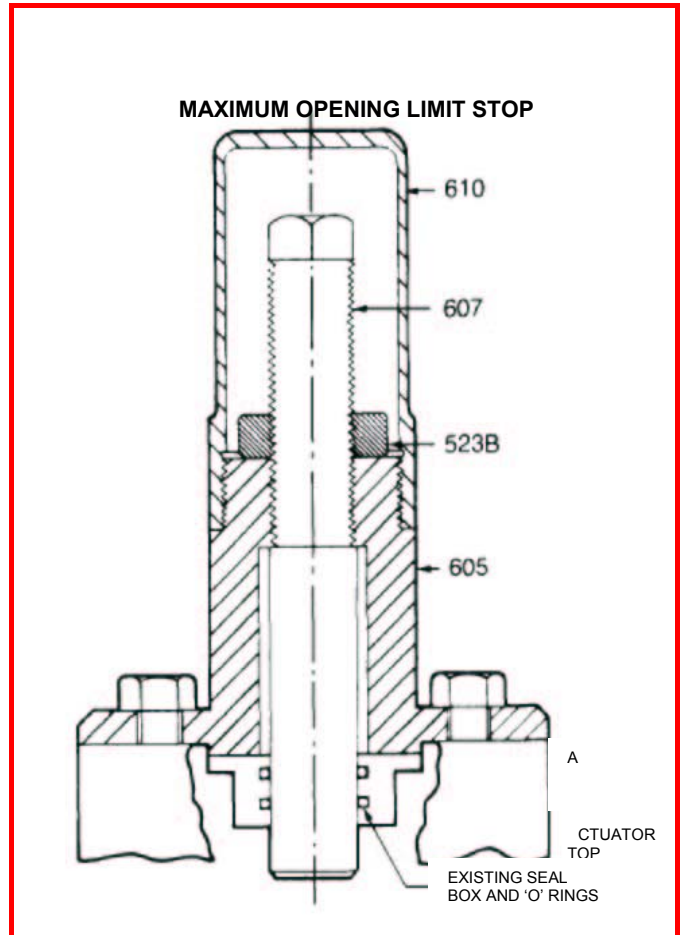

**Maximum Closing -** Restricts downward movement of actuator.

### Installation

1. Remove aluminium cover plate (540) and cover plate joint (559) as supplied on basic actuator.
2. Remove protective cap (610A) and locknuts (523A) from sub-assembly and withdraw spindle (607A).
3. Screw spindle (607A) firmly into the tapped hole at the end of the basic actuator stem (531).

NB – a) On DIRECT actuators, apply smear of light grease or oil to end of spindle (607) where it passes through the seal rings.

b) When screwing spindle (607A) into position, the actuator stem (531) should be prevented from rotating by holding it firmly at the stem coupling.

### Adjustment

1. Apply air to actuator
2. Move actuator up and down whilst adjusting locknuts (523A) until desired travel is obtained.
3. Lock the nuts together and replace cover (610A).

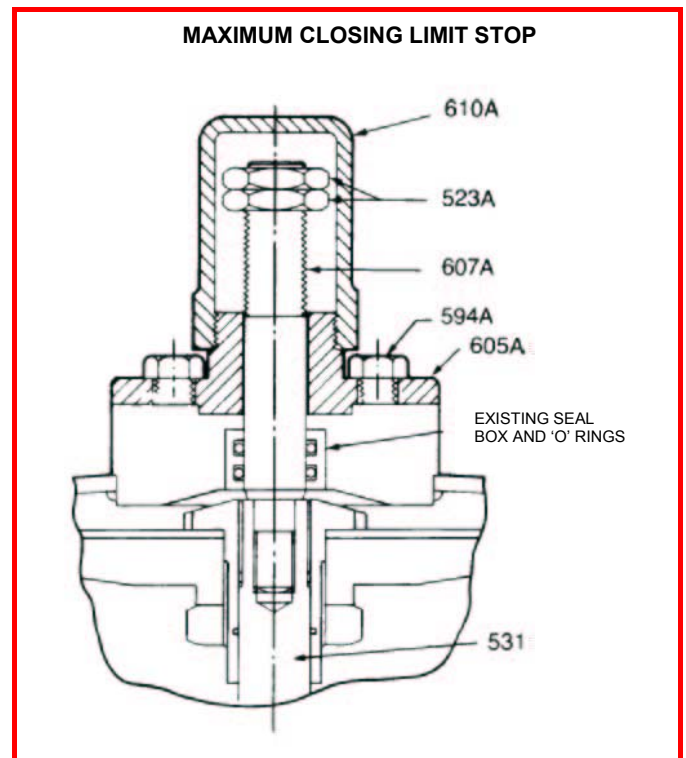

The Company's policy is one of continuous product improvement and the right is reserved to modify the specifications contained herein without notice.

**Koso Kent Intral Ltd.**  
Armytage Road,  
Brighouse, West Yorkshire,  
England. HD6 1QF  
Telephone: Brighouse (01484) 710311.  
Telex: 517281 KENTIV G  
FAX: (01484) 407407

**KOSO**